

—INLAND— Lights and Shapes

Red over red, captain is dead. ☹️

RULE 27: Vessels not under Command or Restricted in Their Ability to Maneuver (RIATM)

(a) ... not under command ...:

(i) **two all-round red lights** ...;

(ii) **two balls** ...; and

(iii) when **making way** through the water, **in addition** to the two all-round red lights, **sidelights** and a **stern light**.

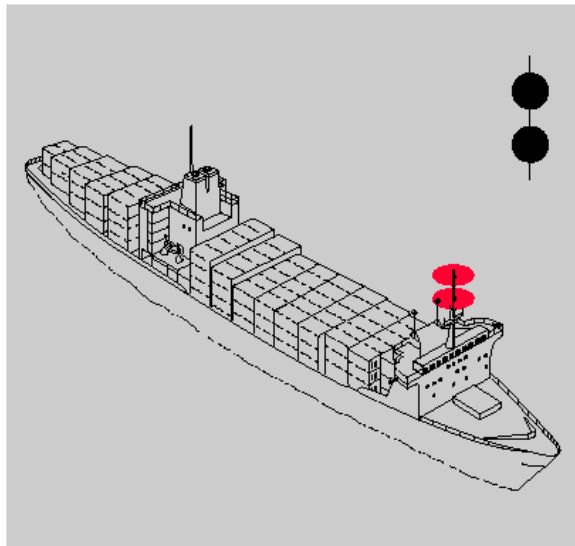

Red over Red  
No other lights

Vessel not under command - **not** making way.  
Same for International.

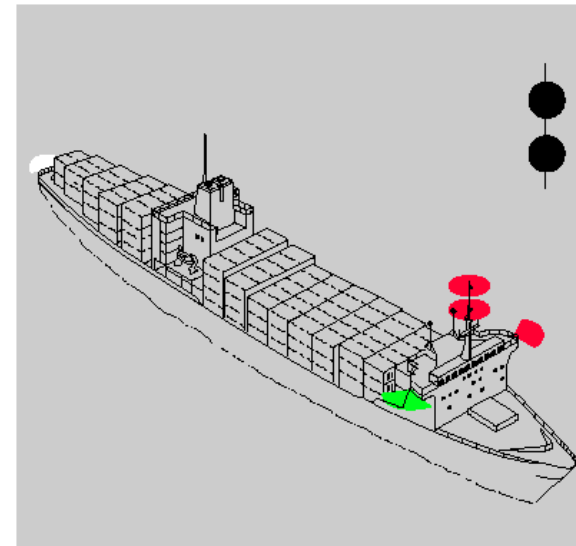

Red over red  
Sidelights  
Stern light  
  
No white masthead  
light(s)

Vessel not under command - **making way**.  
Same for International.

—INLAND— Lights and Shapes

I tried to jam as much info onto each page so it is easier to compare and see the differences. I also listed the changes in my blue comment boxes.

RULE 27: Vessels not under Command or Restricted in Their Ability to Maneuver (RIATM)

(b) RIATM, except a vessel engaged in **mine clearance**, exhibit:

(i) three all-round lights .... **red over white over red**;

(ii) three shapes .... **Ball, diamond, ball**;

(iii) **making way**, add **masthead** lights, **sidelights**, and a **stern light**, to red, over white, over red; and

(iv) at **anchor**, in addition to the RIATM lights or shapes..., light(s) or shapes in Rule 30.

Rule 30: Anchored  
All around white and ball for at anchor <50m.  
50m+ 2 all around white, stern lower and ball.  
100m+ lights to illuminate her decks  
Vessel aground adds 2 all around red and 3 balls  
Will cover later, this is the synopsis

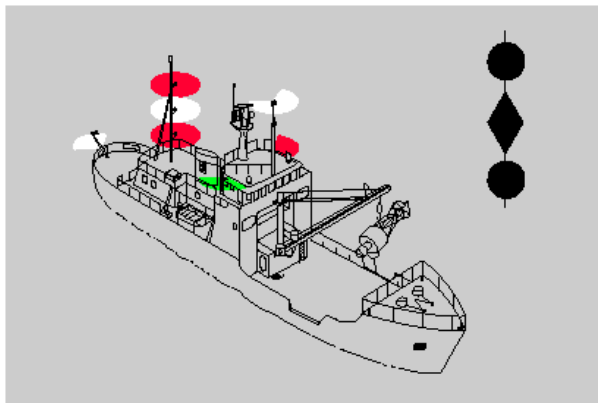

This is the basic rule. The following paragraphs add details for specific operations  
RIATM is red over white over red  
Day shape, ball/diamond/ball

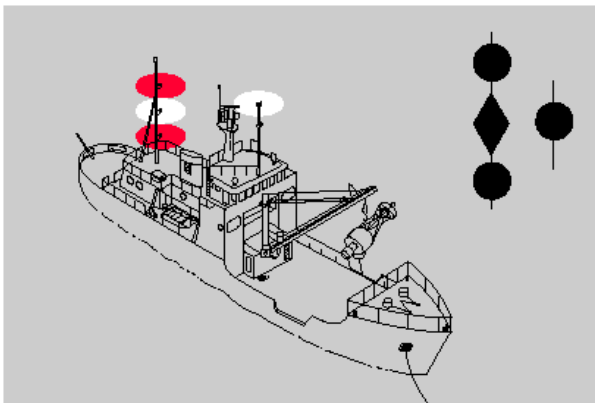

Vessel restricted in her ability to maneuver - **making way**; vessel less than 50 meters in length. Same for International.

Vessel restricted in her ability to maneuver - **at anchor**; vessel less than 50 meters in length. Same for International.

—INLAND— Lights and Shapes

RULE 27: Vessels not under Command or Restricted in Their Ability to Maneuver (RIATM)

(c) towing which severely restricts the towing vessel in ability to deviate from their course shall, in addition to red over white over red and ball diamond ball, exhibit towing light, masthead lights, side lights and stern light.

Adding towing

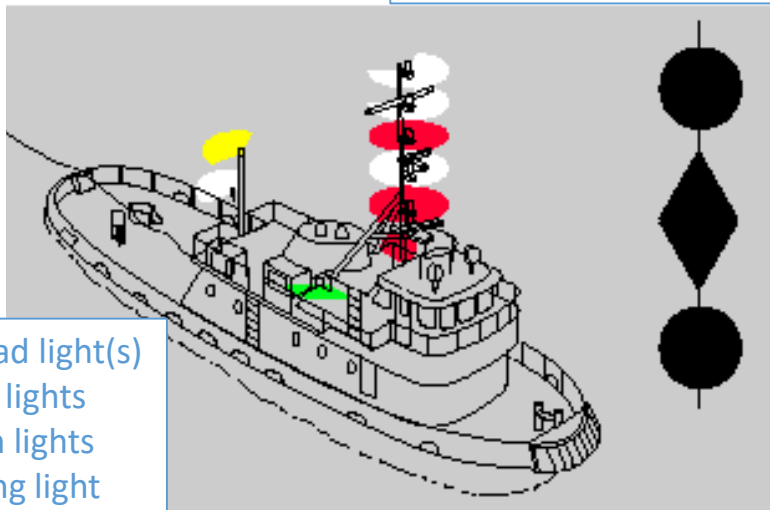

Masthead light(s)  
Side lights  
Stern lights  
Towing light  
Red/white/red

Vessel engaged in towing which severely restricts deviation from their course - length of tow does not exceed 200 meters; towing vessel <50 meters in length. Same for International.

Diving

(d) dredging or underwater operations, when RIATM, exhibit Red/white/red, ball/diamond/ball, and when making way, masthead, side lights, and stern lights, when an obstruction exists, exhibit:

- (i) two all-round red lights or two balls side of obstruction;
- (ii) two all-round green lights or two diamonds (clear) side to pass on; and
- (iii) **at anchor**, the lights or shape prescribed by this paragraph, instead of the lights or shapes prescribed in Rule 30 for anchored vessels.

2 Green good, 2 red bad

Balls bad, diamonds divine

Adding obstruction and clear side to pass

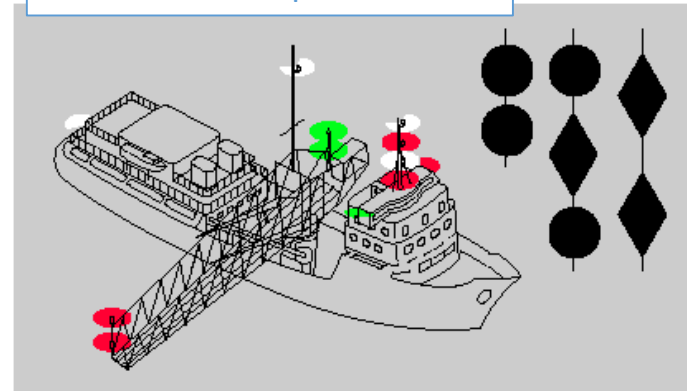

Vessel engaged in dredging or underwater operations when restricted in ability to maneuver - making way with an obstruction on the starboard side. Same for International.

No white anchor light(s) and no one ball for at anchor. They just turn off masthead light, side lights, and stern light

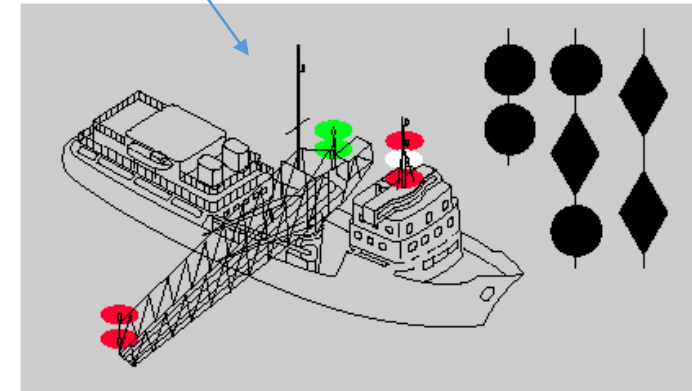

Vessel engaged in dredging or underwater operations when restricted in ability to maneuver - not making way with an obstruction on the starboard side. Same for International.

—INLAND— Lights and Shapes

RULE 27: Vessels not under Command or Restricted in Their Ability to Maneuver (RIATM)

(e) size of a vessel engaged in diving operations **impracticable to exhibit all lights** and shapes prescribed in paragraph (d), following instead:

- (i) Three all-round lights .... **Red over white over red**;
- (ii) A **rigid replica** of the international Code flag "A" not less than 1 meter in height. Ensure all-round visibility.

Size of vessels exemption and adding code "A" flag

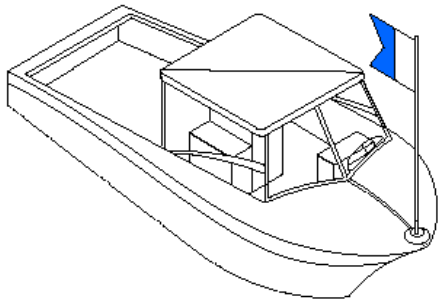

Small vessel engaged in diving operations. Same for International.

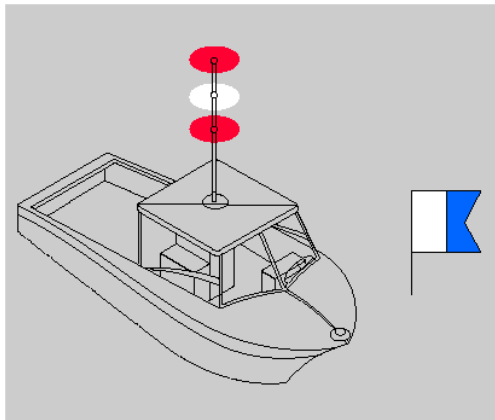

Small vessel engaged in diving operations. Same for International.

(f) **mine clearance** operations, the **lights for a power-driven vessel** in Rule 23 or the **lights or shape** for a vessel at **anchor** in Rule 30, **3 all-round green lights** or **3 balls** at **foremast head** and at **each end** of the **yardarm**.

Dangerous to approach within **1000 meters** of the mine clearance vessel.

Deleting red/white/red and ball/diamond/ball. Replacing with 3 green lights or 3 balls

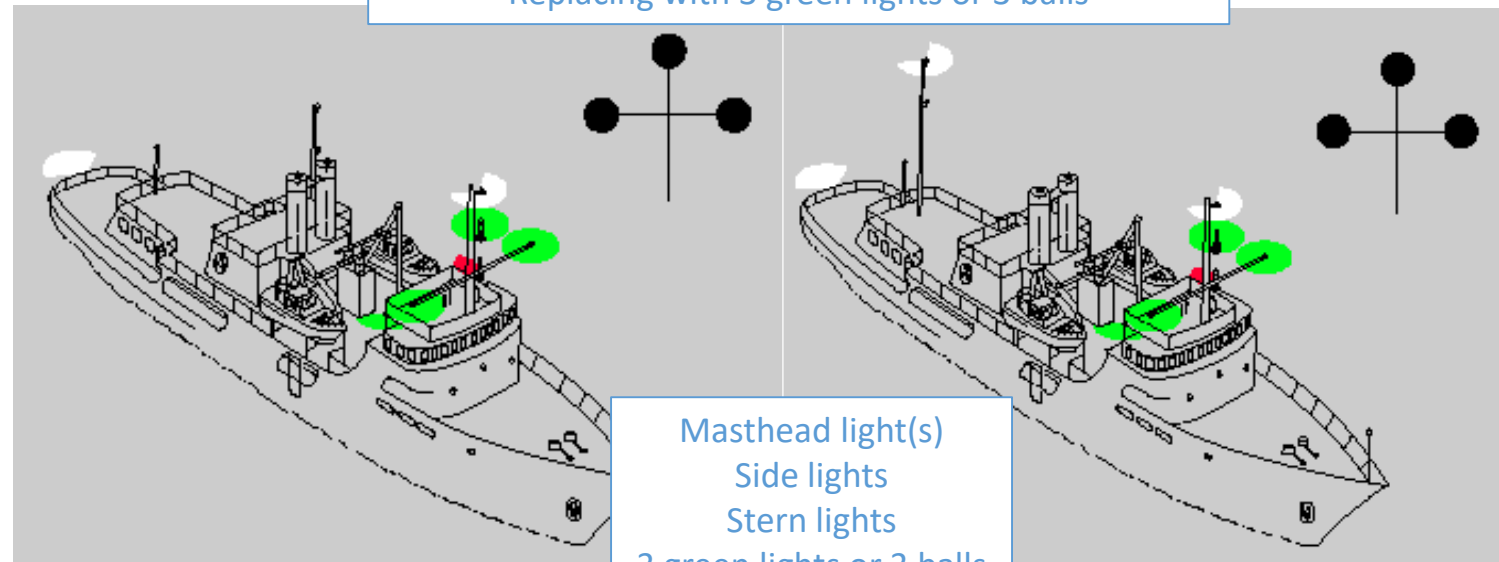

mine clearance operations. < 50 meters. Same for International.

mine clearance operations. 50m+ or <50m showing optional aft masthead light. Same for International.

(g) vessel < 12 meters, **except engaged in diving operations**, not required to exhibit the lights or shapes in Rule 27.

12m = 39.4 feet. U.S. often show the recreational diving flag

